

Pumpenplatten

Elektrokasten
max. 500x500x250

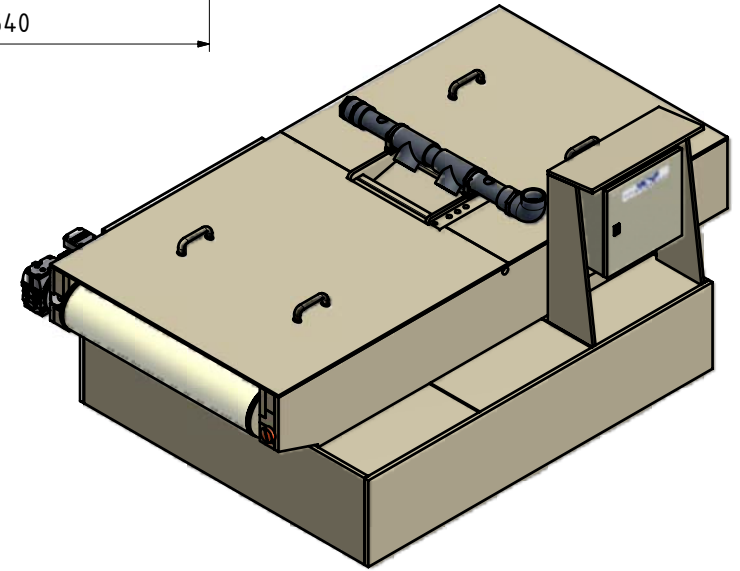

(Oberfl.)	Massstab	1:X	Gewicht	350 Kg
-				

Status	Änderung	Datum	Name	Datum	Name
				Gezeichnet	29.05.2006 MAB
				Kontrolliert	25.07.2005 ZAC
				Norm	

Abmessungen PXF 260

Die Abmessungen sind Richtmasse. Technische Änderungen und Weiterentwicklungen vorbehalten



POSITECH AG
Filtersysteme
CH-5705 Hallwil
Tel. +41 62 767 50 00
Fax. +41 62 767 50 01

819506_ABM

1
A4